

# LARCH - 10Gb/s SFP+ 850nm 300m Optical Transceiver

## Features

- SFP+ package with LC connector
- 850nm VCSEL Laser and PIN photo detector
- Up to 300m transmission on 2000MHz-km MMF
- Up to 11.3Gbps Data Links
- Power dissipation < 1W
- LVPECL compatible data input/output interface
- Low EMI and excellent ESD protection
- laser safety standard IEC-60825 compliant
- Compatible with RoHS
- Compatible with SFF8472

## Application

- 10GBASE-SR/SW 10G Ethernet
- 1200-Mx-SN-I 10G Fiber Channel

## Absolute Maximum Ratings

Parameter	Symbol	Minimum	Maximum	Units
Storage Temperature	Tst	-40	+85	°C
Supply Voltage	Vcc	0	+3.6	V
Operating Relative Humidity	RH	0	85	%

## Operation Environment

Parameter		Symbol	Min	Typical	Max	Units
Supply Voltage		Vcc	3.15		3.45	V
Operating Case Temp	Commercial	Tc	0		+70	°C
Power Dissipation					1	W
Data Rate				10.3125		Gbps

## Optical Characteristics

(Ambient Operating Temperature 0°C to +70°C, Vcc =3.3 V)

Parameter	Symbol	Min.	Typ.	Max.	Units
<b>Transmitter Section</b>					
Center Wavelength	$\lambda_o$	840	850	860	nm
RMS Spectral Width	$\Delta\lambda$	-	-	0.45	dB
Average Output Power	Po	-5	-	0	dBm
Extinction Ratio	Er	3.0	-	-	dB
Dispersion Penalty				3.9	dB
Relative Intensity Noise	RIN <sub>12</sub> OMA			-128	dB/Hz
Total jitter	Tj	IEEE 802.3ae			
<b>Receiver Section</b>					
Center Wavelength	$\lambda_o$		850		nm
Receiver Sensitivity	Rsen			-11.5	dBm
Stressed Sensitivity	Rsen			-10.5	dBm
Receiver Overload	Rov	0			dBm
Return Loss		12			dB
LOS Assert	LOS <sub>A</sub>	-25			dBm
LOS Dessert	LOS <sub>D</sub>			-13	dBm
LOS Hysteresis		0.5		4	

## Electrical Characteristics

(Ambient Operating Temperature 0°C to +70°C, Vcc =3.3 V)

Parameter		Symbol	Min.	Typ.	Max.	Unit
<b>Transmitter Section</b>						
Input Differential Impedence		Zin	90	100	110	Ohm
Data Input Swing Differential		Vin	180		700	mV
TX Disable	Disable		2.0		Vcc	V
	Enable		0		0.8	V
TX Fault	Assert		2.0		Vcc	V
	Deassert		0		0.8	V
<b>Receiver Section</b>						
Output differential impedance		Zout		100		Ohm
Data output Swing Differential		Vout	300		800	mV
Rx_LOS	Assert		2.0		Vcc	V
	Deassert		0		0.8	V

## Maximum Supported Distances

Parameter		Symbol	Min.	Typ.	Max.	Unit
Fiber Type	850nm OFL Band Width					
62.5 um	160MHz-km				26	m
	200MHz-km				33	m
50 um	400MHz-km				66	m
	500MHz-km				82	m
	2000MHz-km				300	m

## Diagnostics

Parameter	Range	Accuracy	Unit	Calibration
Temperature	-5 ~ 75	±5	°C	Internal
Voltage	3.15 ~ 3.45	0.1	V	Internal
Bias Current	0 ~ 12	1	mA	Internal
Tx Power	-8 ~ 1	±2	dBm	Internal
Rx Power	-18 ~ -3	±3	dBm	Internal

## EEPROM INFORMATION (A0)

Addr	Field Size (Bytes)	Name of Field	HEX	Description
0	1	Identifier	03	SFP
1	1	Ext. Identifier	04	MOD4
2	1	Connector	07	LC
3-10	8	Transceiver	10 00 00 00 00 00 00 00	Transmitter Code
11	1	Encoding	06	64B66B
12	1	BR, nominal	67	1000M bps
13	1	Reserved	00	
14	1	Length (9um)-km	00	
15	1	Length (9um)	00	
16	1	Length (50um)	08	
17	1	Length (62.5um)	02	
18	1	Length (copper)	00	
19	1	Reserved	00	
20-35	16	Vendor name	57 49 4E 54 4F 50 20 20 20 20 20 20 20 20 20 20	OEM
36	1	Reserved	00	
37-39	3	Vendor OUI	00 00 00	
40-55	16	Vendor PN	xx xx xx xx xx xx xx xx xx xx xx xx xx xx xx xx	ASC II
56-59	4	Vendor rev	31 2E 30 20	V1.0
60-61	2	Wavelength	03 52	850nm
62	1	Reserved	00	
63	1	CC BASE	XX	Check sum of byte 0~62
64-65	2	Options	00 1A	LOS, TX_DISABLE, TX_FAULT
66	1	BR, max	00	
67	1	BR, min	00	
68-83	16	Vendor SN	00 00 00 00 00 00 00 00 00 00 00 00 00 00 00 00	Unspecified
84-91	8	Vendor date code	XX XX XX 20	Year, Month, Day
92-94	3	Reserved	00	
95	1	CC_EXT	XX	Check sum of byte 64~94
96-255	160	Vendor specific		

## Pin Description

Pins	Name	Description	Note
1	VeeT	Transmitter Ground	
2	Tx Fault	Transmitter Fault Indication	1
3	Tx Disable	Transmitter Disable	2
4	MOD DEF2	Module Definition 2	3
5	MOD DEF1	Module Definition 1	3
6	MOD DEF0	Module Definition 0	3
7	RS0	Not Connected	
8	LOS	Loss of Signal	4
9	RS1	Not Connected	
10	VeeR	Receiver Ground	
11	VeeR	Receiver Ground	
12	RD-	Inv. Received Data Output	5
13	RD+	IReceived Data Output	5
14	VeeR	Receiver Ground	
15	VccR	Receiver Power	
16	VccT	Transmitter Power	
17	VeeT	Transmitter Ground	
18	TD+	Transmit Data Input	6
19	TD-	Inv. Transmit Data Input	6
20	VeeT	Transmitter Ground	

**Notes:**

1. TX Fault is an open collector output, which should be pulled up with a 4.7k~10kΩ resistor on the host board to a voltage between 2.0V and Vcc+0.3V. Logic 0 indicates normal operation; logic 1 indicates a laser fault of some kind. In the low state, the output will be pulled to less than 0.8V.
2. TX Disable is an input that is used to shut down the transmitter optical output. It is pulled up within the module with a 4.7k~10kΩ resistor. Its states are:  
Low (0~0.8V): Transmitter on  
(>0.8V, <2.0V): Undefined  
High (2.0~3.465V): Transmitter Disabled  
Open: Transmitter Disabled
3. MOD-DEF 0,1,2 is the module definition pins. They should be pulled up with a 4.7k~10kΩ resistor on the host boards. The pull-up voltage shall be VccT or VccR.  
MOD-DEF 0 is grounded by the module to indicate that the module is present  
MOD-DEF 1 is the clock line of two wire serial interface for serial ID  
MOD-DEF 2 is the data line of two wire serial interface for serial ID
4. LOS is an open collector output, which should be pulled up with a 4.7k~10kΩ resistor on the host board to a voltage between 2.0V and Vcc+0.3V. Logic 0 indicates normal operation; logic 1 indicates loss of signal. In the low state, the output will be pulled to less than 0.8V.
5. These are the differential receiver output. They are internally AC-coupled 100Ω differential lines which should be terminated with 100Ω (differential) at the user SERDES.
6. These are the differential transmitter inputs. They are AC-coupled, differential lines with 100Ω differential termination inside the module.

# Recommended Application Circuit

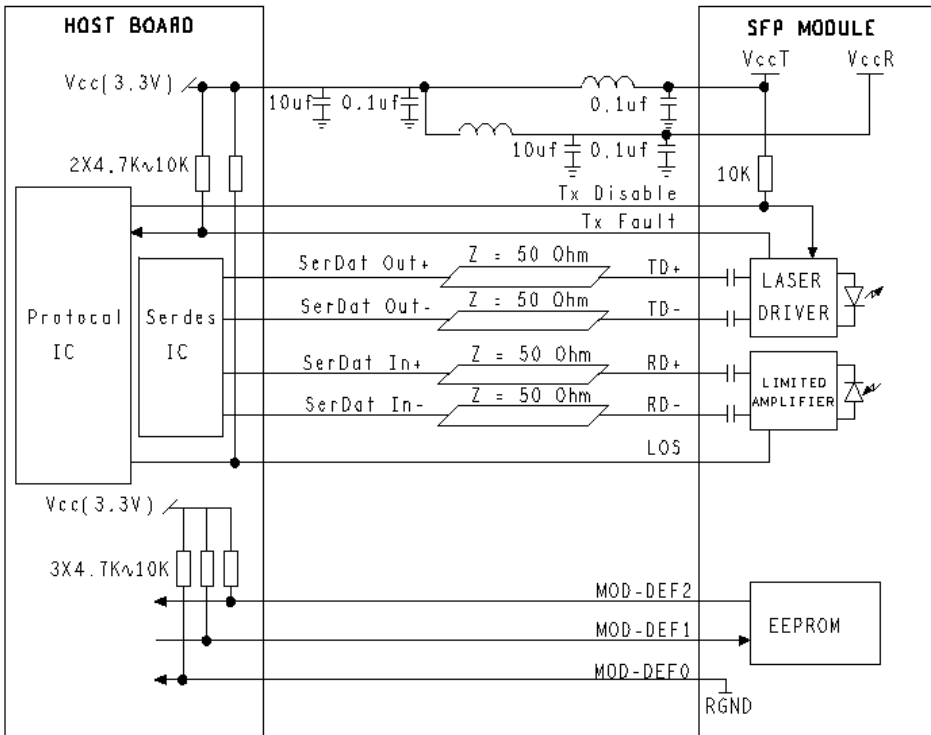

# Outline Drawing (mm)

